

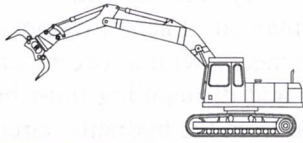

10) SCHEMES

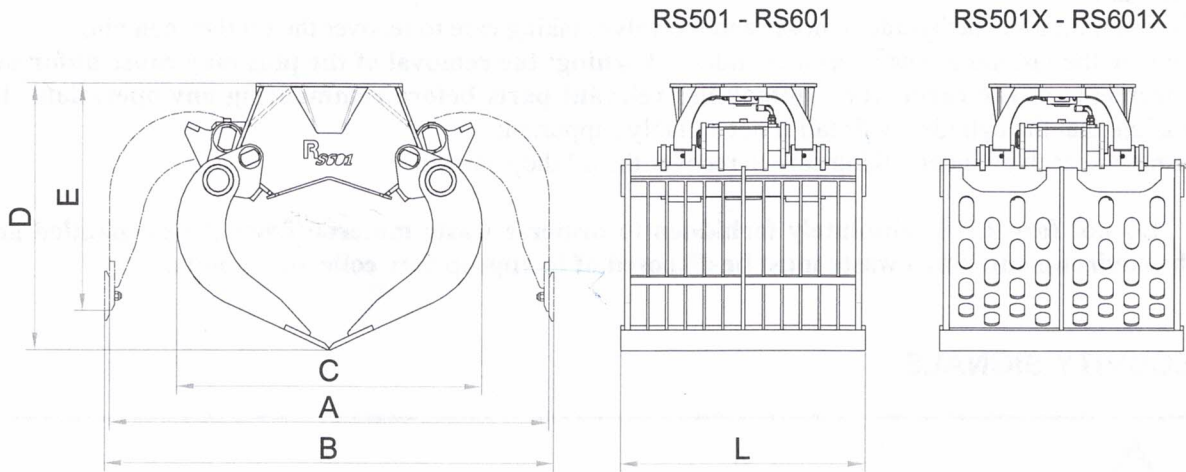

PESO ESCAVATORE
EXCAVATOR WEIGHT 13t - 19 t RS501
POIDS DE LA PELLE 14 t - 20 t RS601
BAGGER GEWICHTSKLASSE



MODELLO - MODEL MODÈLE - MODELL		RS501SR RS501XSR	RS601SR RS601XSR
CAPACITÀ - CAPACITY CAPACITÉ - INHALT	dm ³	500	600
PESO - WEIGHT POIDS - GEWICHT	Kg	930 890 (X)	990 940 (X)
PRESSIONE - PRESSURE PRESSION - DRUCK	bar	350	350
FORZA ALLA LAMA - TOOTH FORCE PUISSANCE À LA LAME SCHLIEßKRAFT JE SCHALE	Kg	4860	4860
DIMENSIONI SIZES DIMENSIONS ABMESSUNGEN	A	1800	1800
	B	1840	1840
	C	1250	1250
	D	960	960
	E	920	920
	L	850	1000
	Schema 1 ; Scheme 1 ; Schéma 1 ; Zeichnung 1		
	Serie, Range, Série, Reihe: RS 501 - 601		